

# KA63 // THE COSHOCTON

DECORATIVE ARM

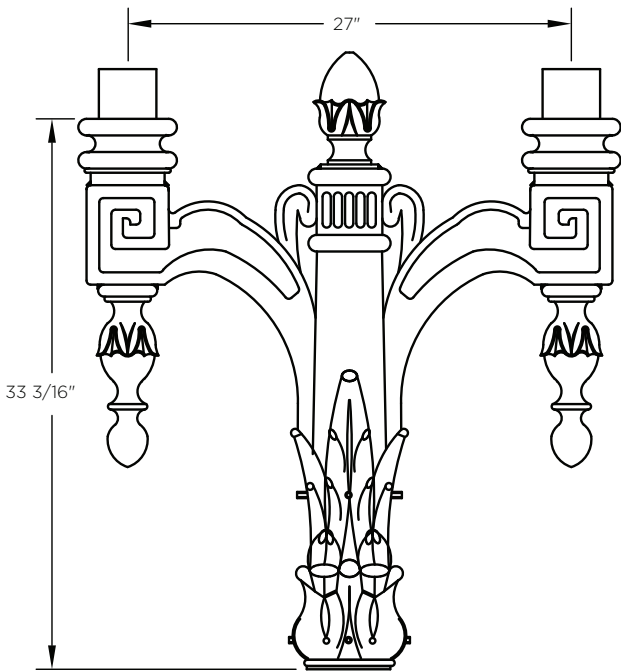

The King Luminaire KA63 Arm is an eye catching design with exceptional detail. This arm is available in single or double arm configurations. The KA63 offers a stand-out solution with historical style.

## ARM SPECIFICATIONS

**MATERIAL:**  
Aluminum

**MOUNTING TYPE:**  
Tenon

**ARM QUANTITY:**  
Single  
Double

**ARM LENGTH:**  
Fixed Length:

**FINISH:**  
Available in textured or smooth.

**EPA**  
1.47 - 3.8 sq. ft.

**WEIGHT**  
23 - 46 lbs

### MOUNTING TYPES:

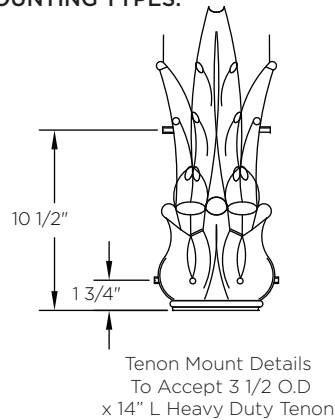

## HOW TO ORDER

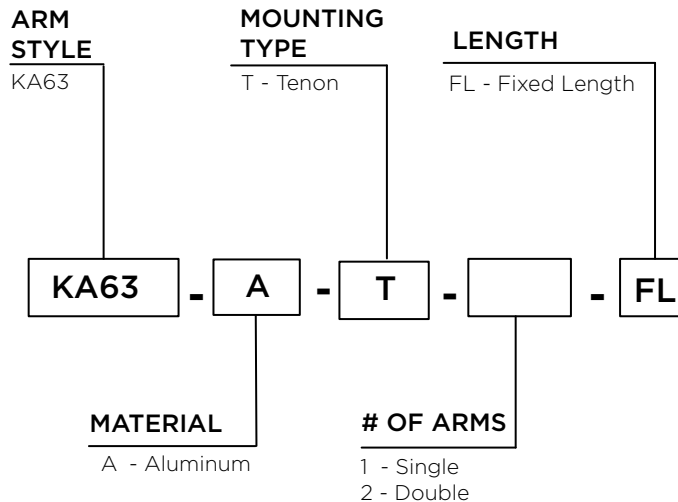

## EPA & WEIGHT

Catalog Number	Mount Type	# of Arms	L. (in)	EPA (sq ft)	Wt. (lbs)
KA63-A-T-1-FL	Tenon	1	N/A	1.47	23
KA63-A-T-2-FL	Tenon	2	27"	3.8	46

