

KA150 // OCTAGONAL SLIP OVER ALUMINUM ARM

STREET LIGHT ARM

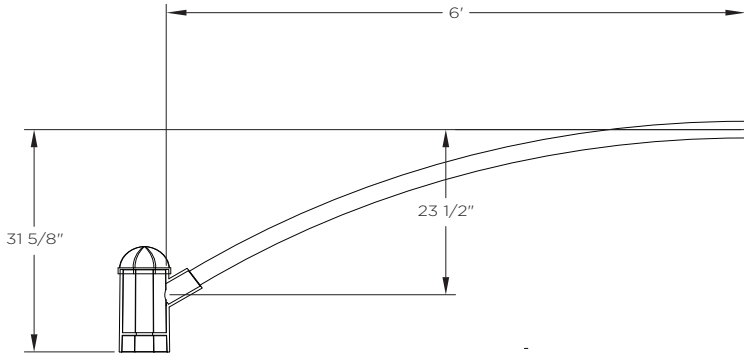

The King Luminaire KA150 Octagonal Slip Over Arm is a sleek and innovative design.

ARM SPECIFICATIONS

- MATERIAL:**
Aluminum
- MOUNTING TYPE:**
Tenon
- ARM QUANTITY:**
Single
Double
- ARM LENGTHS:**
4'
6'
8'
10'
- FINISH:**
Available in textured or smooth.
- EPA**
1.70 - 5.37 sq. ft.
- WEIGHT**
19 - 51 lbs

MOUNTING DETAILS:

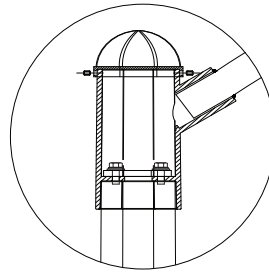

Octagonal Mount Details suitable for 5-3/8" fl/fl pole top

ARM DIMENSIONS:

Run	Rise
4'	17 5/16"
6'	23 1/2"
8'	29 9/16"
10'	36"

LEVELING DEVICE:

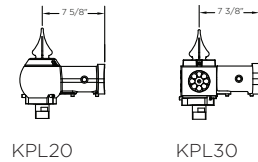

*See leveling device spec sheet for more options

HOW TO ORDER

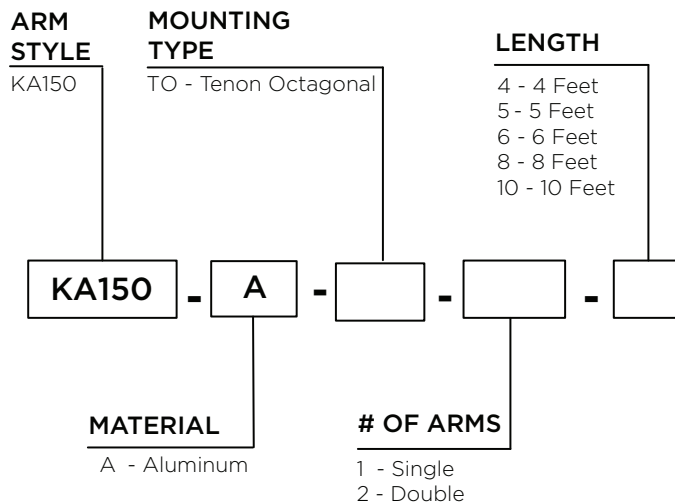

EPA & WEIGHT

Catalog Number	Mount Type	# of Arms	L. (ft)	EPA (sq ft)	Wt. (lbs)
KA150-A-TO-1-4	TO	1	4	1.70	19
KA150-A-TO-1-5	TO	1	5	1.93	22.5
KA150-A-TO-1-6	TO	1	6	2.21	25
KA150-A-TO-1-8	TO	1	8	2.66	28
KA150-A-TO-1-10	TO	1	10	3.10	32
KA150-A-TO-2-4	TO	2	4	2.66	25
KA150-A-TO-2-5	TO	2	5	3.13	26
KA150-A-TO-2-6	TO	2	6	3.67	39
KA150-A-TO-2-8	TO	2	8	4.58	46
KA150-A-TO-2-10	TO	2	10	5.37	51

