

# BA // MULTIPLE MOUNTING CONFIGURATIONS

## BANNER ARMS & BANNER SAVERS



The King Luminaire Banner Arms and Banner Savers come in multiple mounting configurations to suit the physical and aesthetic requirements of your project. Available in both single and double arm configurations for single or paired banners.

## ARM SPECIFICATIONS

### MOUNTING CONFIGURATION:

Single  
Double

### MOUNTING TYPE:

Threaded Coupling  
Non-Threaded Coupling  
Cast Clamp-On (Large)  
Cast Clamp-On (Small)  
Fabricated Clamp-On  
Side Channel  
Banner Saver

### MATERIAL:

Aluminum  
Fiberglass (Banner Saver Only)

### ARM LENGTHS:

12"  
18"  
24"  
30"

### ARM O.D.:

1 5/16"  
3/4" (Banner Saver Only)

### FINISH:

Available in textured or smooth.

### WEIGHT

1.5 - 9.2 lbs

### MOUNTING TYPES:

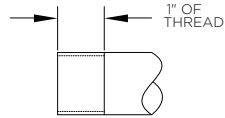

Threaded Coupling  
(s/f Concrete Poles)

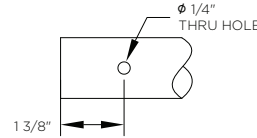

Non-Threaded Coupling  
(s/f Metal Poles)

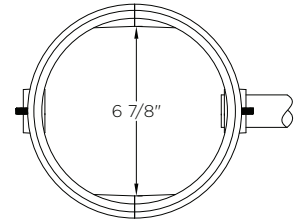

Cast Clamp-On (Large)  
(s/f 5 1/4" - 6 1/2" O.D. or FLAT/FLAT Pole)

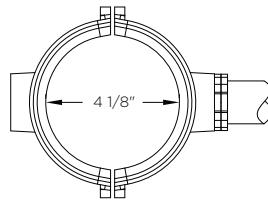

Cast Clamp-On (Small)  
(s/f 4" O.D. pole)

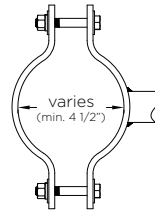

Fabricated Clamp-On  
(s/f varying shaft sizes -  
min. 4 1/2" O.D.)

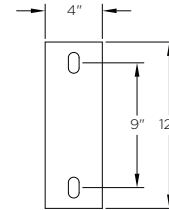

Side Channel

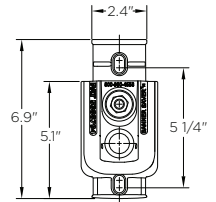

Banner Saver

## HOW TO ORDER

### MOUNTING CONFIGURATION

SBA - Single Banner Arm  
DBA - Double Banner Arm

### MOUNTING TYPE

CT - Threaded Coupling  
CN - Non-Threaded Coupling  
CL - Cast Clamp-On (Large)  
CS - Cast Clamp-On (Small)  
CO - Fabricated Clamp-On  
SC - Side Channel  
BS - Banner Saver

### PAINT COLOR

GN - Federal Green  
BE - Blue  
GY - Gray  
BN - Brown  
BK - Black  
BZ - Bronze

\*Additional options available on website. BK will be provided if blank.



### MATERIAL

A - Aluminum  
F - Fiberglass\*

\*only available in Banner Saver

### LENGTH

12 - 12"  
18 - 18"  
24 - 24"  
30 - 30"

### DECORATIVE DETAIL

BB - Removable Banner Ball

# CONFIGURATION OPTIONS

# THREADED COUPLING

**MOUNTING CONFIGURATION:**

Single  
Double

**MATERIAL:**

Aluminum

**ARM O.D.:**

1 5/16"

**MOUNTING TYPE:**

Threaded Coupling  
(s/f Concrete Poles)

**ARM LENGTHS:**

12"  
18"  
24"  
30"

**FINISH:**

Available in textured or smooth.

**WEIGHT**

1.5 - 5.3 lbs

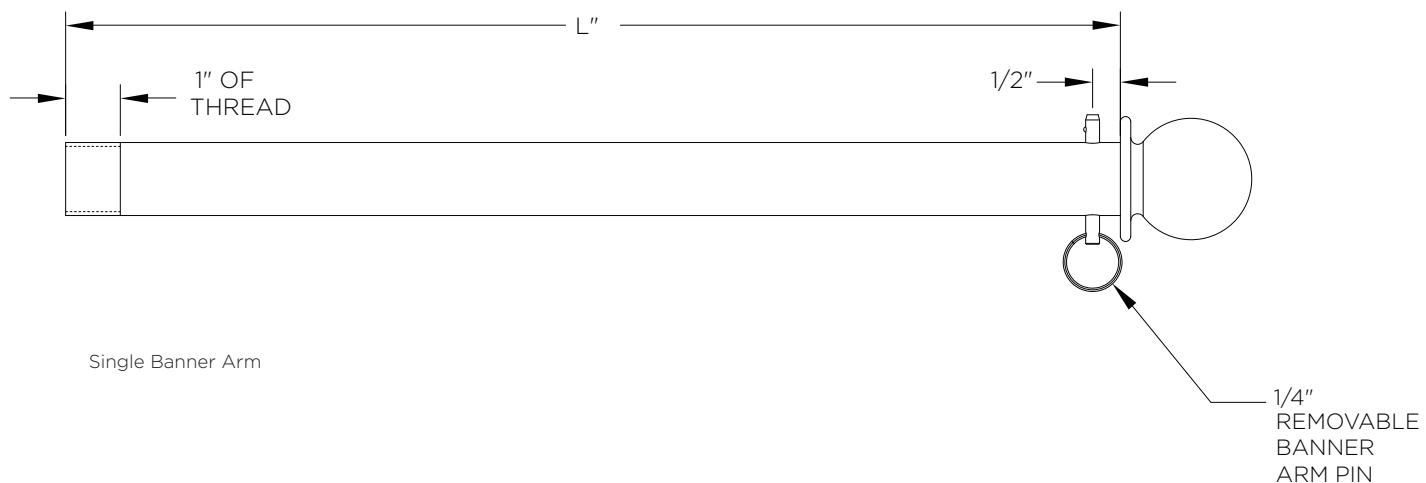

Single Banner Arm

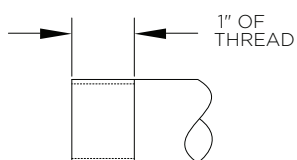

Mounting Details

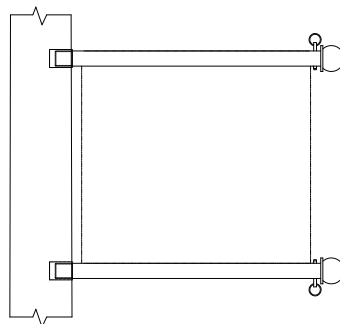

2x Single Banner Arms with banner

## WEIGHT

Catalog Code	Mount Type	# of Arms	L. (in)	Wt. (lbs)
SBA-CT-A-12-BB	Threaded Coupling	1	12	1.5
SBA-CT-A-18-BB	Threaded Coupling	1	18	1.9
SBA-CT-A-24-BB	Threaded Coupling	1	24	2.3
SBA-CT-A-30-BB	Threaded Coupling	1	30	2.7
DBA-CT-A-12-BB	Threaded Coupling	2	12	3.0
DBA-CT-A-18-BB	Threaded Coupling	2	18	3.8
DBA-CT-A-24-BB	Threaded Coupling	2	24	4.6
DBA-CT-A-30-BB	Threaded Coupling	2	30	5.3

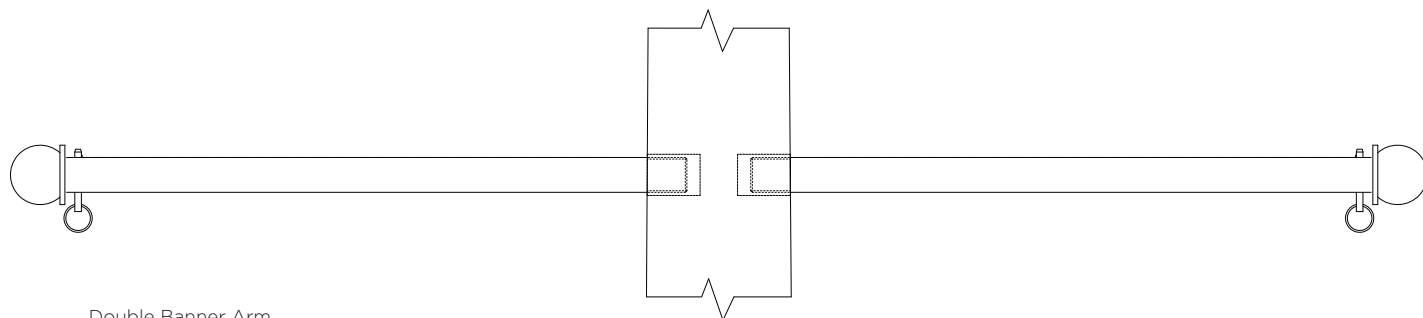

Double Banner Arm

# CONFIGURATION OPTIONS

## NON-THREADED COUPLING

**MOUNTING CONFIGURATION**

Single  
Double

**MOUNTING TYPE:**

Non-Threaded Coupling  
(s/f Metal Poles)

**MATERIAL:**

Aluminum

**ARM LENGTHS:**

12"  
18"  
24"  
30"

**ARM O.D.:**

1 5/16"

**FINISH:**

Available in textured or smooth.

**WEIGHT**

1.6 - 5.4 lbs

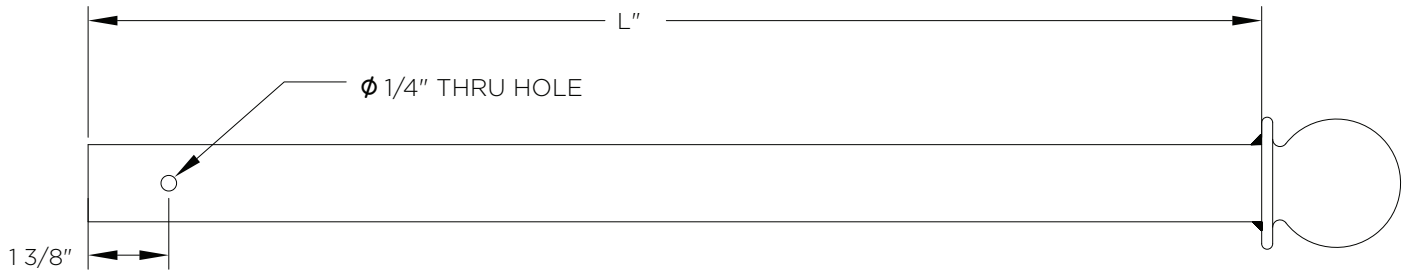

Single Banner Arm

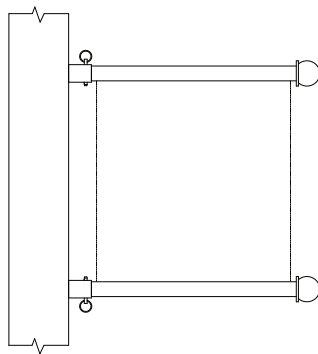
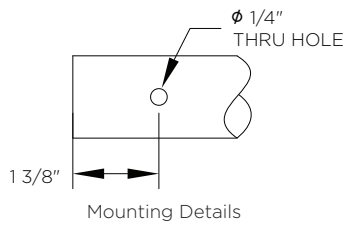

2x Single Banner Arms with banner

### WEIGHT

Catalog Code	Mount Type	# of Arms	L. (in)	Wt. (lbs)
SBA-CN-A-12-BB	Non-Threaded Coupling	1	12	1.6
SBA-CN-A-18-BB	Non-Threaded Coupling	1	18	1.9
SBA-CN-A-24-BB	Non-Threaded Coupling	1	24	2.3
SBA-CN-A-30-BB	Non-Threaded Coupling	1	30	2.7
DBA-CN-A-12-BB	Non-Threaded Coupling	2	12	3.1
DBA-CN-A-18-BB	Non-Threaded Coupling	2	18	3.9
DBA-CN-A-24-BB	Non-Threaded Coupling	2	24	4.6
DBA-CN-A-30-BB	Non-Threaded Coupling	2	30	5.4

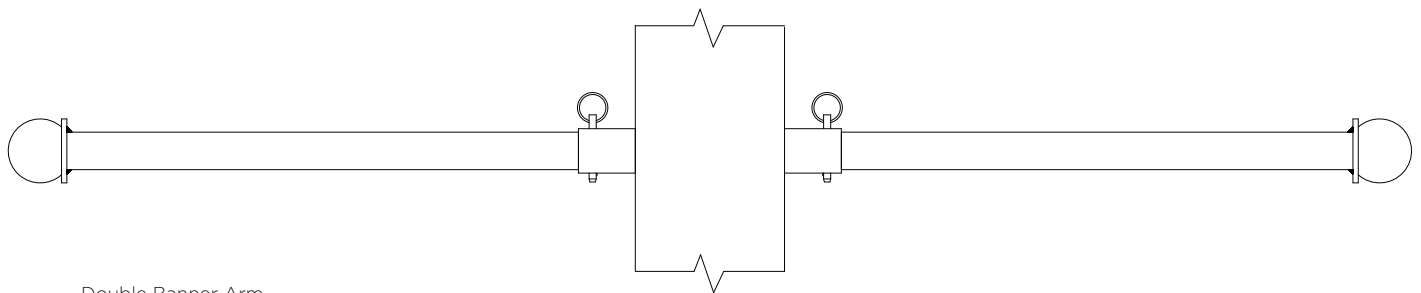

Double Banner Arm

# CONFIGURATION OPTIONS

## CAST CLAMP-ON (LARGE)

**MOUNTING CONFIGURATION:**

Single  
Double

**MATERIAL:**

Aluminum

**ARM O.D.:**

1 5/16"

**MOUNTING TYPE:**

Cast Clamp-On (Large)  
(s/f 5 1/4" - 6 1/2" O.D. or FLAT/FLAT Pole)

**ARM LENGTHS:**

12"  
18"  
24"  
30"

**FINISH:**

Available in textured or smooth.

**WEIGHT**

5.4 - 9.1 lbs

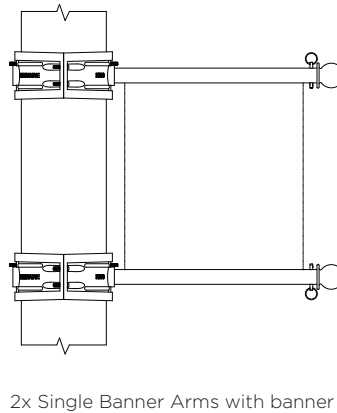
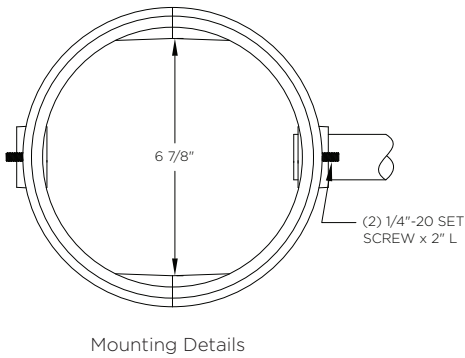
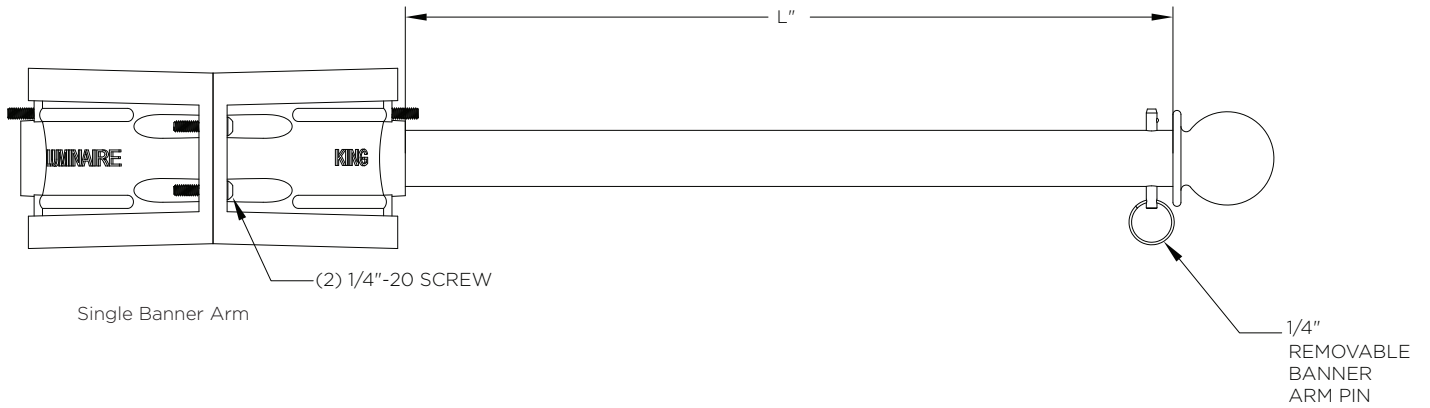

### WEIGHT

Catalog Code	Mount Type	# of Arms	L. (in)	Wt. (lbs)
SBA-CL-A-12-BB	Cast Clamp-On (Large)	1	12	5.4
SBA-CL-A-18-BB	Cast Clamp-On (Large)	1	18	5.7
SBA-CL-A-24-BB	Cast Clamp-On (Large)	1	24	6.1
SBA-CL-A-30-BB	Cast Clamp-On (Large)	1	30	6.5
DBA-CL-A-12-BB	Cast Clamp-On (Large)	2	12	6.8
DBA-CL-A-18-BB	Cast Clamp-On (Large)	2	18	7.6
DBA-CL-A-24-BB	Cast Clamp-On (Large)	2	24	8.3
DBA-CL-A-30-BB	Cast Clamp-On (Large)	2	30	9.1

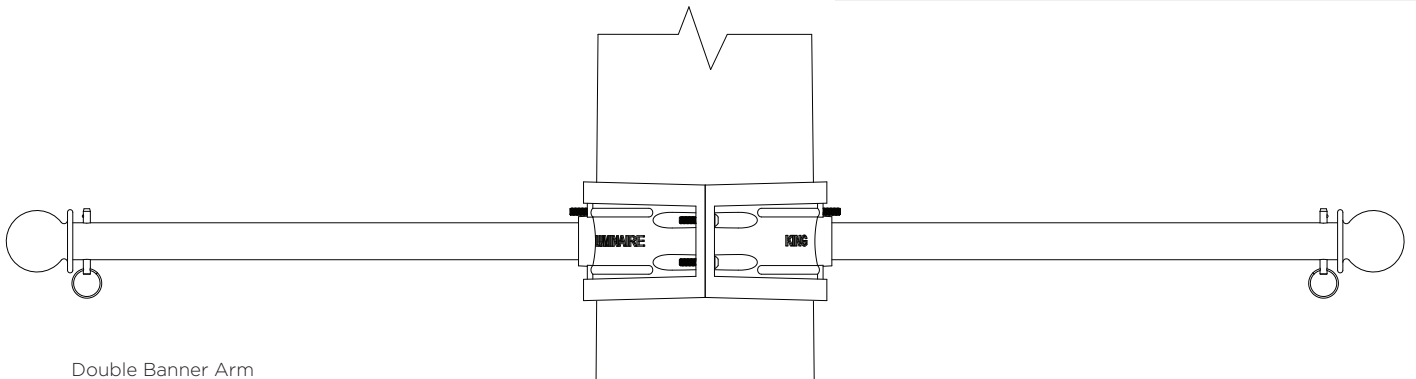

# CONFIGURATION OPTIONS

## CAST CLAMP-ON (SMALL)

### MOUNTING CONFIGURATION:

Single  
Double

### MATERIAL:

Aluminum

### ARM O.D.:

1 5/16"

### MOUNTING TYPE:

Cast Clamp-On (Small)  
(s/f 4" O.D. Pole)

### ARM LENGTHS:

12"  
18"  
24"  
30"

### FINISH:

Available in textured or smooth.

### WEIGHT

3.5 - 9.2 lbs

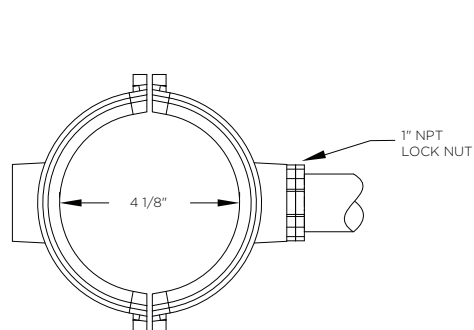
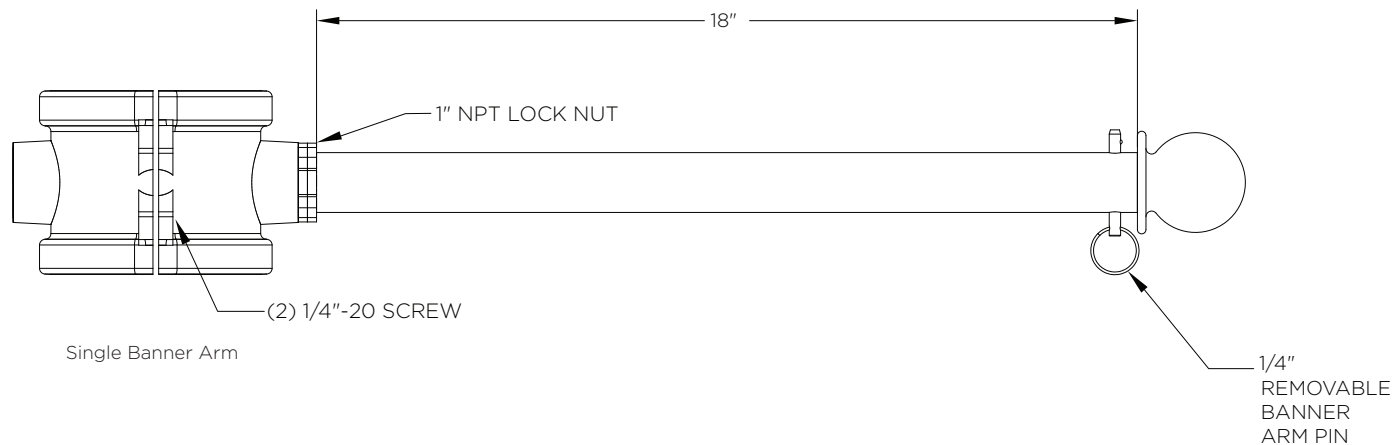

Mounting Details

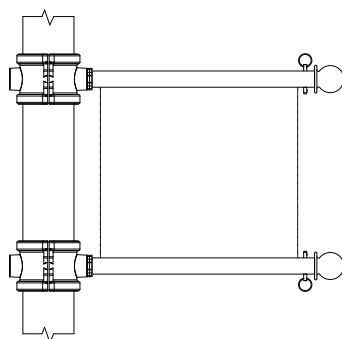

2x Single Banner Arms with banner

## WEIGHT

Catalog Code	Mount Type	# of Arms	L. (in)	Wt. (lbs)
SBA-CS-A-12-BB	Cast Clamp-On (Small)	1	12	3.5
SBA-CS-A-18-BB	Cast Clamp-On (Small)	1	18	3.8
SBA-CS-A-24-BB	Cast Clamp-On (Small)	1	24	4.2
SBA-CS-A-30-BB	Cast Clamp-On (Small)	1	30	4.6
DBA-CS-A-12-BB	Cast Clamp-On (Small)	2	12	6.9
DBA-CS-A-18-BB	Cast Clamp-On (Small)	2	18	7.7
DBA-CS-A-24-BB	Cast Clamp-On (Small)	2	24	8.4
DBA-CS-A-30-BB	Cast Clamp-On (Small)	2	30	9.2

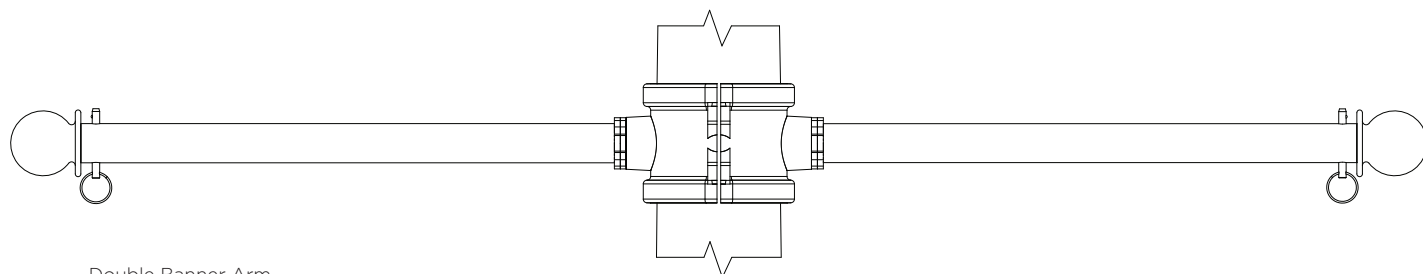

Double Banner Arm

# CONFIGURATION OPTIONS

FABRICATED CLAMP-ON

**MOUNTING CONFIGURATION:**

Single  
Double

**MATERIAL:**

Aluminum

**ARM O.D.:**

1 5/16"

**MOUNTING TYPE:**

Fabricated Clamp-On  
(s/f varying shaft sizes -  
minimum 4 1/2" O.D. Pole)

**ARM LENGTHS:**

12"  
18"  
24"  
30"

**FINISH:**

Available in textured or smooth.

**WEIGHT**

4.9 - 8.5 lbs

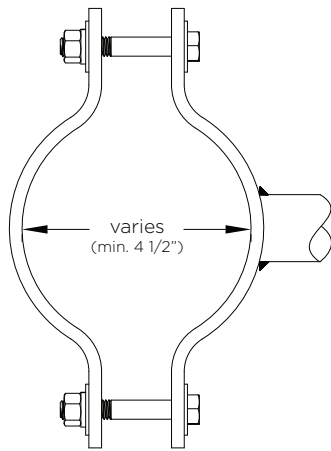
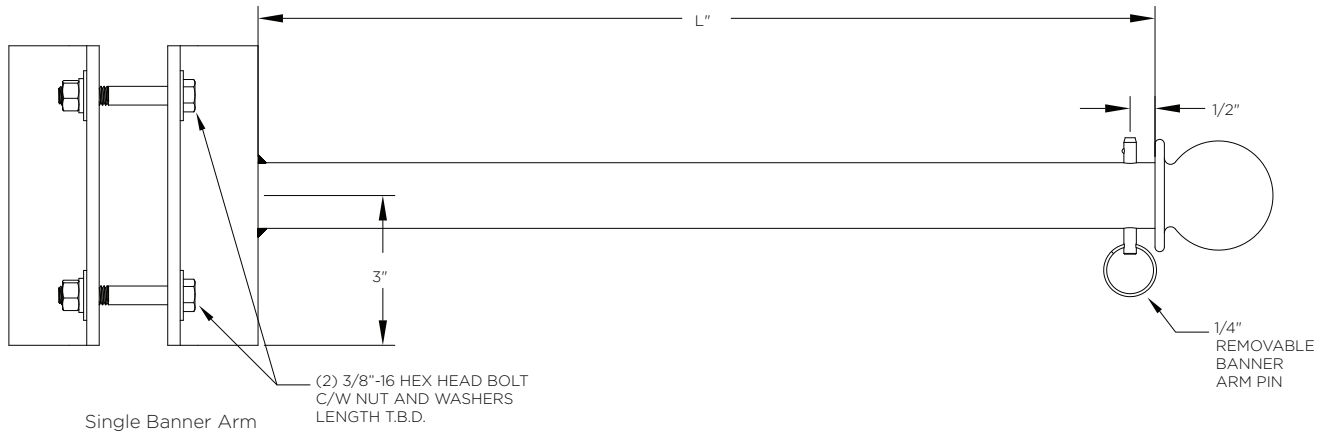

Mounting Details

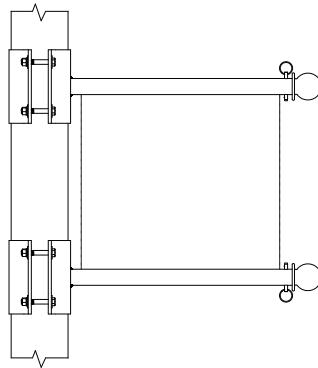

2x Single Banner Arms with banner

## WEIGHT

Catalog Code	Mount Type	# of Arms	L. (in)	Wt. (lbs)
SBA-CO-A-12-BB	Fabricated Clamp-On	1	12	4.9
SBA-CO-A-18-BB	Fabricated Clamp-On	1	18	5.2
SBA-CO-A-24-BB	Fabricated Clamp-On	1	24	5.6
SBA-CO-A-30-BB	Fabricated Clamp-On	1	30	6.0
DBA-CO-A-12-BB	Fabricated Clamp-On	2	12	6.3
DBA-CO-A-18-BB	Fabricated Clamp-On	2	18	7.0
DBA-CO-A-24-BB	Fabricated Clamp-On	2	24	7.8
DBA-CO-A-30-BB	Fabricated Clamp-On	2	30	8.5

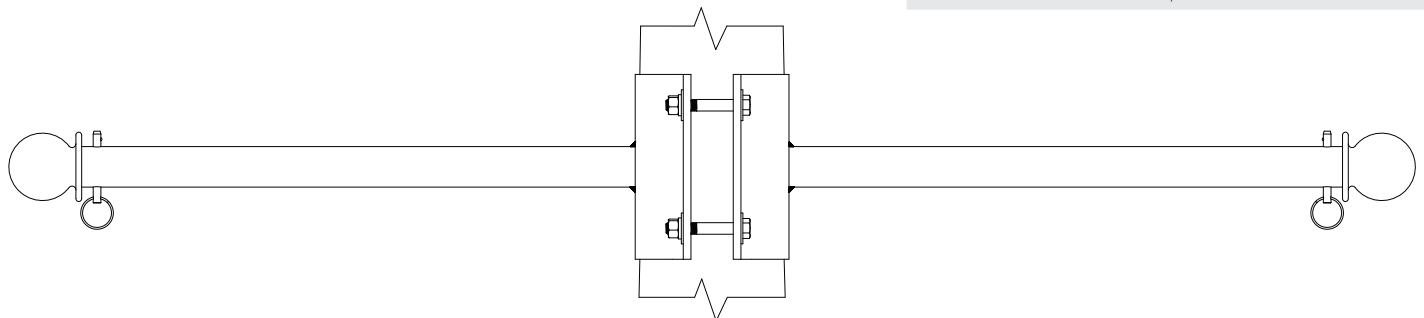

Double Banner Arm

# CONFIGURATION OPTIONS

## SIDE CHANNEL

### MOUNTING CONFIGURATION:

Single  
Double

### MATERIAL:

Aluminum

### ARM O.D.:

1 5/16"

### MOUNTING TYPE:

Side Channel

### ARM LENGTHS:

12"  
18"  
24"  
30"

### FINISH:

Available in textured or smooth.

### WEIGHT

3.5 - 9.2 lbs

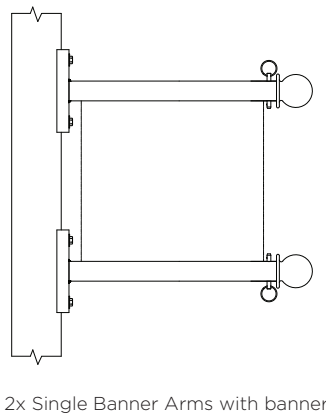
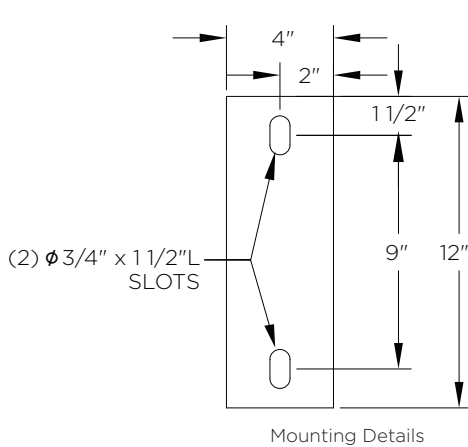
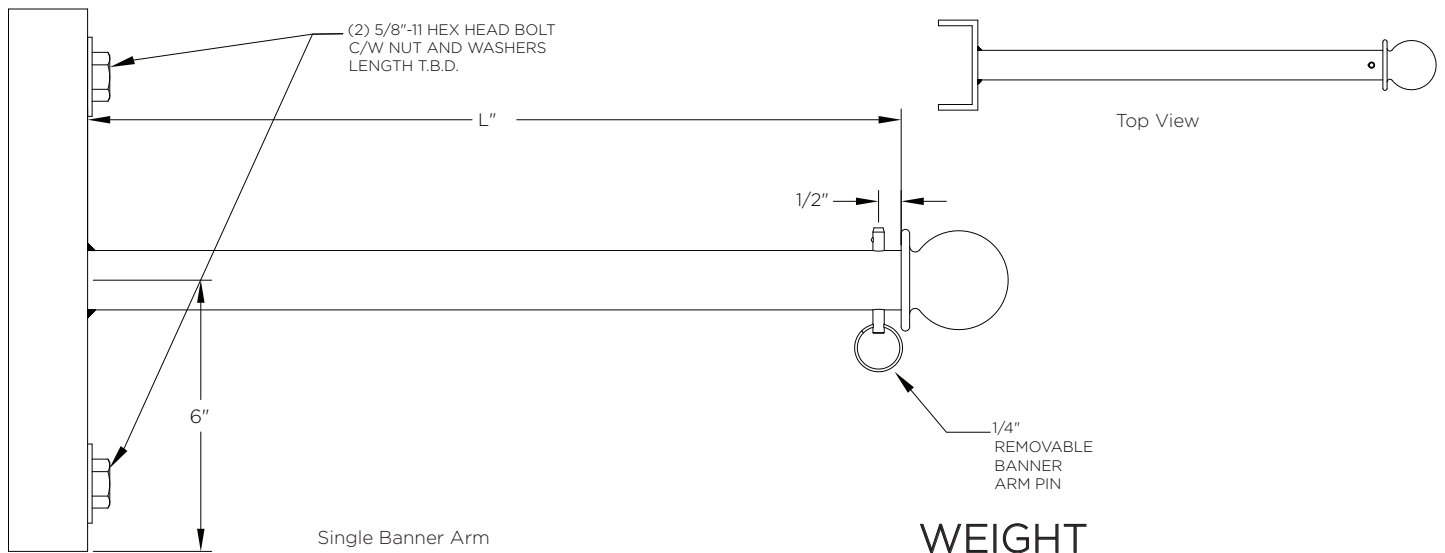

## WEIGHT

Catalog Code	Mount Type	# of Arms	L. (in)	Wt. (lbs)
SBA-SC-A-12-BB	Side Channel	1	12	3.5
SBA-SC-A-18-BB	Side Channel	1	18	3.8
SBA-SC-A-24-BB	Side Channel	1	24	4.2
SBA-SC-A-30-BB	Side Channel	1	30	4.6
DBA-SC-A-12-BB	Side Channel	2	12	7.0
DBA-SC-A-18-BB	Side Channel	2	18	7.7
DBA-SC-A-24-BB	Side Channel	2	24	8.4
DBA-SC-A-30-BB	Side Channel	2	30	9.2

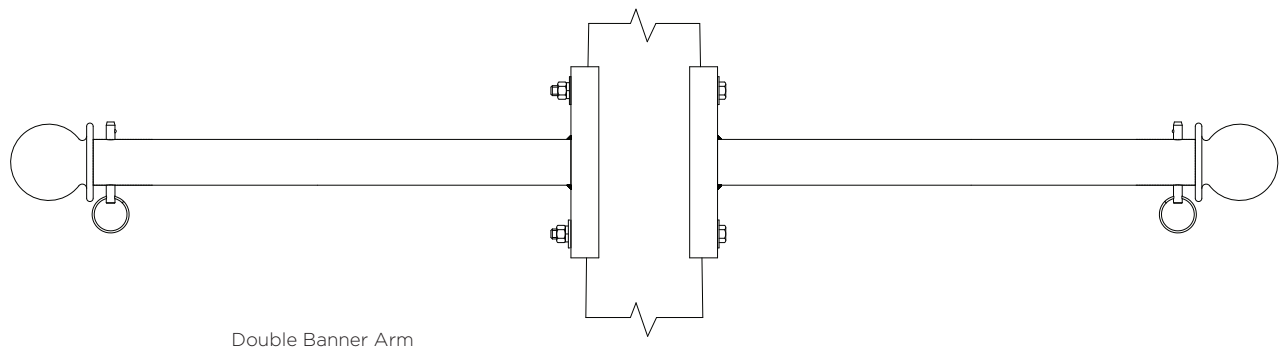

# CONFIGURATION OPTIONS

BANNER SAVER

**MOUNTING CONFIGURATION:**

Single  
Double

**MATERIAL:**

Fiberglass

**ARM O.D.:**

3/4"

**MOUNTING TYPE:**

Banner Saver  
(max. banner size of 20 ft<sup>2</sup>)

**ARM LENGTHS:**

12" (Max. banner height: 20")  
18" (Max. banner height: 13")  
24" (Max. banner height: 10")  
30" (Max. banner height: 8")

**FINISH:**

Available in textured or smooth.

**WEIGHT**

4.0 - 9.1 lbs

*Designed to release 80%+ of wind loading;  
keeping your banners and poles intact.*

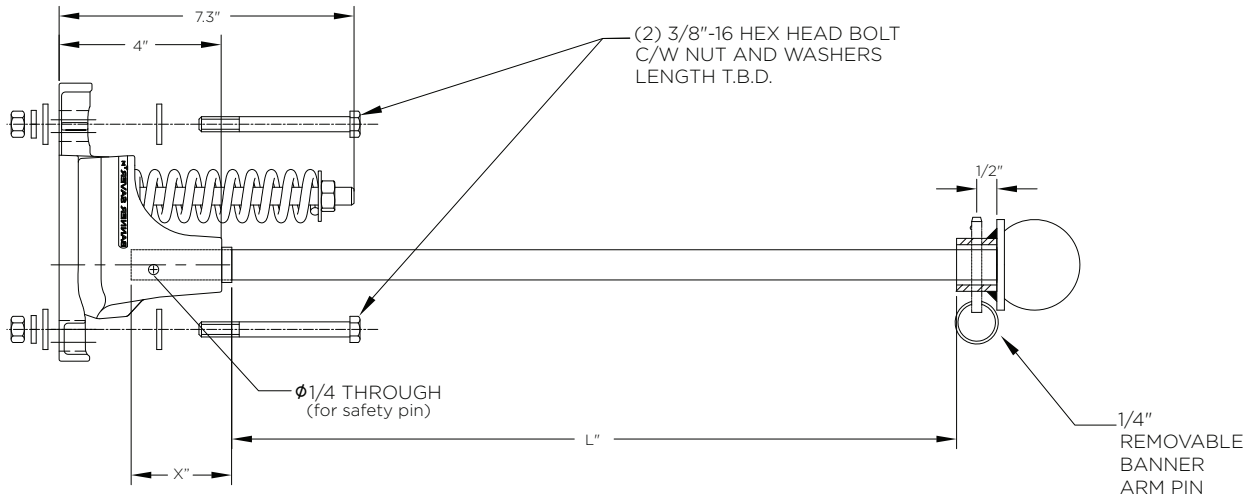

Single Banner Saver

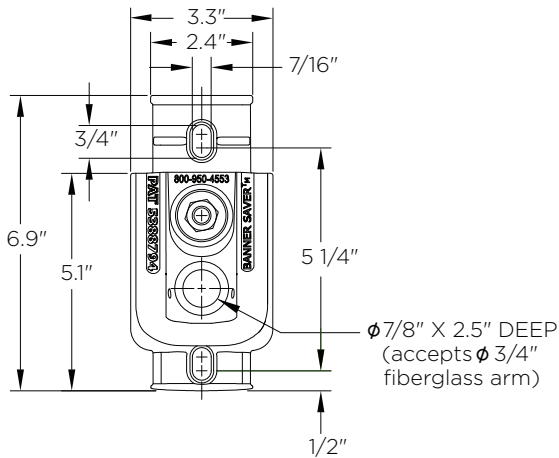

Mounting Details

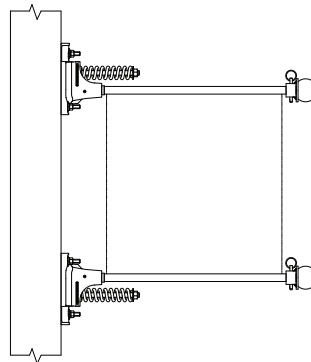

1 Set of Single Banner Savers with banner

## WEIGHT

Catalog Code	Mount Type	# of Arms	L. (in)	Wt. (lbs)
SBA-BS-F-12-BB	Banner Saver	1	12	4.0
SBA-BS-F-18-BB	Banner Saver	1	18	4.2
SBA-BS-F-24-BB	Banner Saver	1	24	4.4
SBA-BS-F-30-BB	Banner Saver	1	30	4.5
DBA-BS-F-12-BB	Banner Saver	2	12	8.1
DBA-BS-F-18-BB	Banner Saver	2	18	8.4
DBA-BS-F-24-BB	Banner Saver	2	24	8.7
DBA-BS-F-30-BB	Banner Saver	2	30	9.1

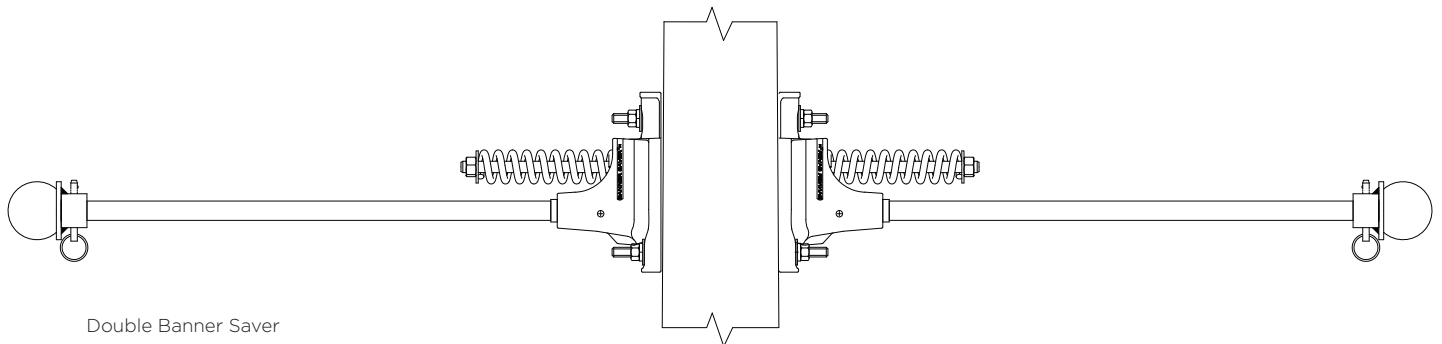

Double Banner Saver